

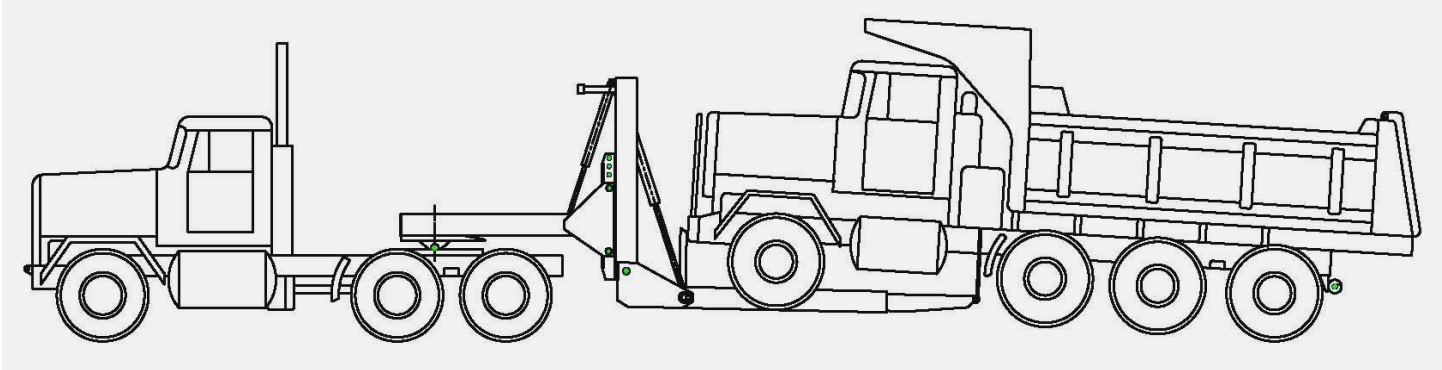

TRU-HITCH, INC. • 16 WEST WEST HILL RD. BARKHAMSTED, CT 06063
1-860-489-7773 • Fax 1-860-489-8786 • 1-800-450-8659

Manufacturers of Patented Truck Trailering Lifts



Operating Instruction Manual

Read All Instructions Before Operating

Tru-Hitch* Model 250 & 250P

<u>Specification</u>	<u>Standard</u>	<u>Severe Service Option</u>
Gross Lift Capacity	25,000 lbs.	30,000 lbs.
Trailering Capacity	80,000 lbs. G.C.W	120,000 lbs. G.C.W.
Hitch Weight with Attachments	6,700 lbs.	7,200 lbs.
Hydraulic Operating Pressure	3,000 psi	3,000 psi

Tru-Hitch* is the safest device for transporting a truck. The versatility or the Tru-Hitch*'s fifth wheel hitch allows any truck to be transported as a semi-trailer, allowing optimal weight distribution between tractor and trailer.

*Tru-Hitch is a registered trademark

Tru-Hitch* Components

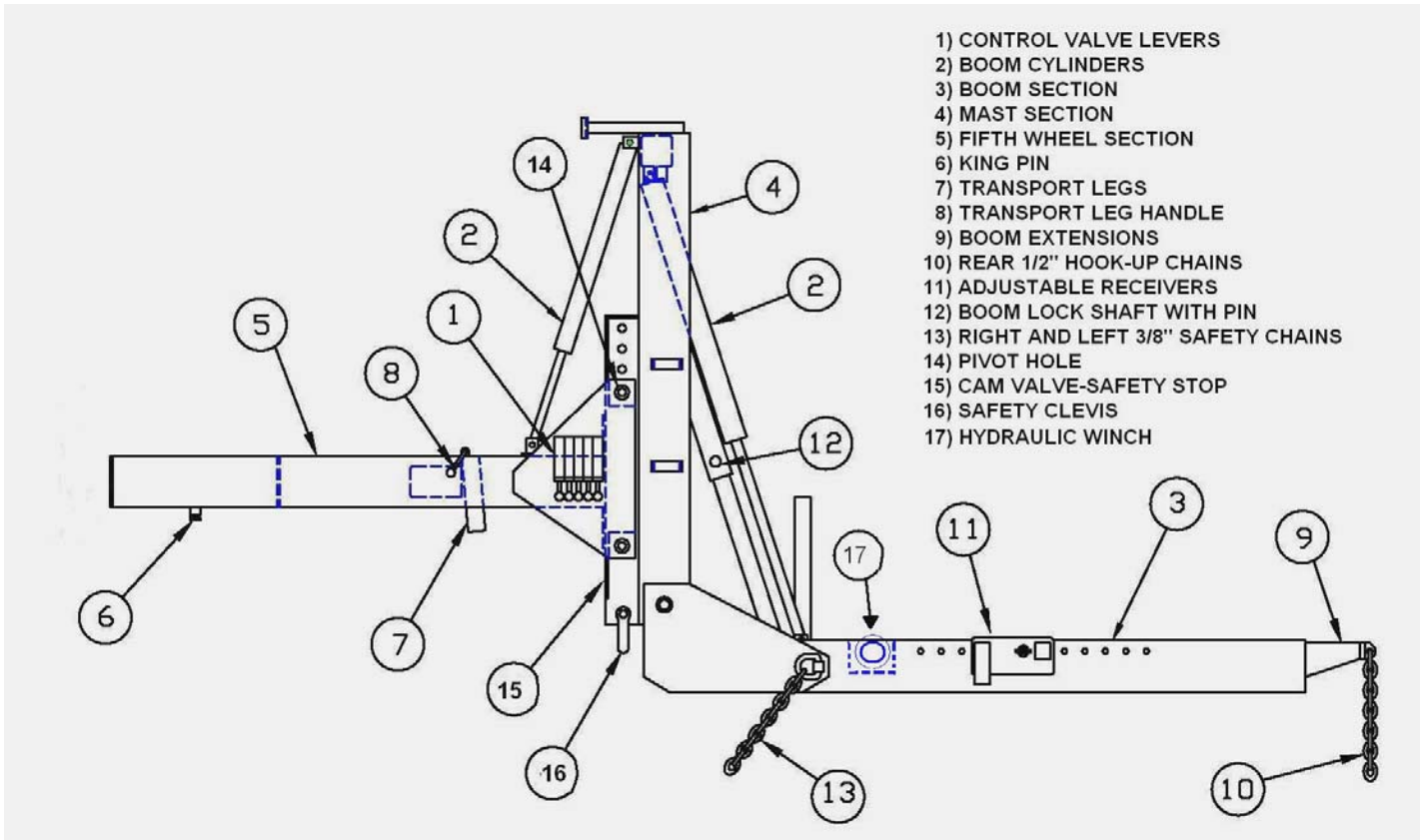
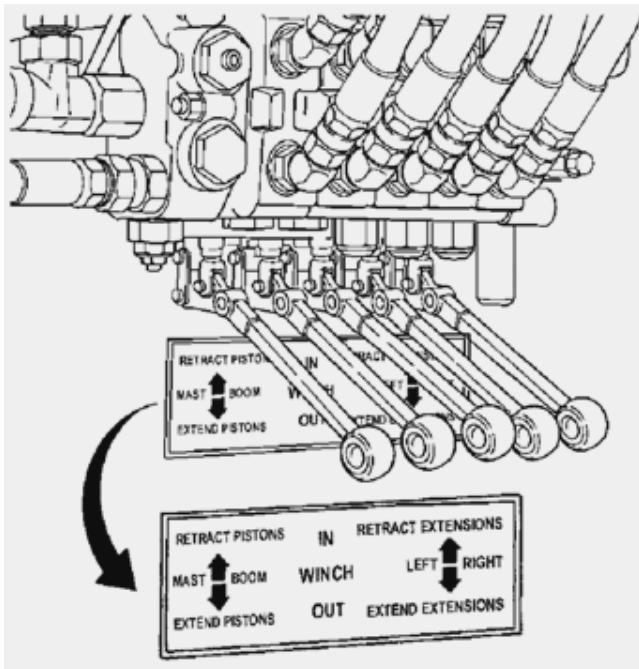
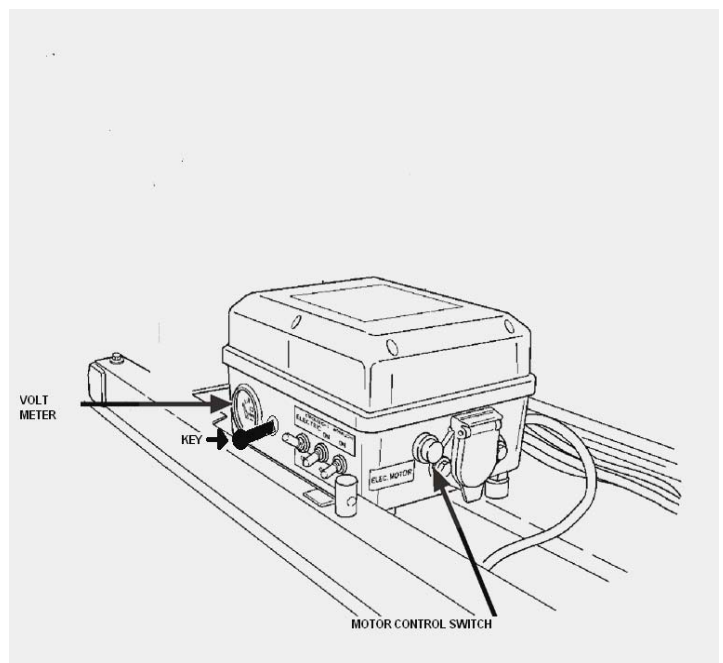

Figure A



**Control valve levers (#1)
 Figure B**



**Electric Control Box
 Figure C**

Principle of Operation

1. Refer to Figure A for the part names for the Tru-Hitch*
2. The majority of these procedures are performed with only the first two control valve levers, the MAST and the BOOM levers. Keep this in mind as you learn to use the hitch.
3. The control valve levers activate hydraulic pistons to extend or retract. For instance, if the boom *lever is pressed down, the pistons extend* and the angle between the boom and the Mast (the boom angle) is increased. If the boom *valve lever is pushed up, the pistons retract* and the boom angle is decreased. When the weight of the truck is resting on the booms, the effect of increasing (extend) boom angle is to raise the end of the truck that is resting on the booms. If the boom angle is decreased (retract), the effect is to lower the end of the truck that is resting on the boom. These raising and lowering effects occur because of the pivoting motion of the Tru-Hitch*. Operators should become familiar with the extension and retraction action of the hydraulic pistons before using the Tru-Hitch* to transport a truck.
4. The flow control valves are used to keep some back pressure in the hydraulic system. There is a flow control valve for the mast and one for the boom hydraulics. They are adjusted by turning the knob as needed. **With no load** on the hitch you want to have approximately 500-800 psi of back pressure showing on the hitch pressure gauge. You can adjust the mast pressure when *retracting* the mast in the track and you can adjust the boom when you are *extending* the boom down into the tow position. Once set, you should not have to re-adjust unless outside temperatures (cold/hot), when using the hitch, change the flow of the hydraulic oil.

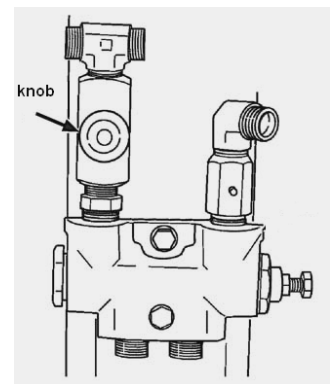

Flow valve

Operating Procedures

- Notes:** A. if not using wetlines of tractor, the electric control box must be set to “electric” and the motor control switch must be depressed to use valve control levers.
B. The remote control can be used where instructed to use valve control levers.

1. Initial coupling to tractor to the Tru-Hitch*

The operating procedures assume that initially the Tru-Hitch* is set on the ground with the boom extended at a right angle to the Mast section as shown in figure A. To ready the Tru-Hitch* for coupling to the tractor, turn the key to the “on” position and use the control lever to engage the hydraulic system. (Tractor should be positioned close enough to attach wetlines and engage PTO.) *Extend or Retract* the mast pistons as necessary to position the king pin on the fifth wheel section (5) level with the tractors fifth wheel. Back the tractor under the horizontal frame until the king pin engages the fifth wheel and is latched. Carefully re-check the latch to make sure the king pin is fully engaged. **Note: make sure that the transport legs (7) are in stored position prior to backing under the Tru-Hitch* to prevent damage to the legs.**

2. Procedure to transport the Tru-Hitch without a load

A. Use the control lever to *extend* the boom angle until the fifth wheel section(5) lifts sufficiently to allow the rear support legs (7) to be lowered down over the tractor's after-frame. To lower the supports, rotate the handle (8) clockwise and lock them into place. Once locked use the control lever to *retract* the boom and rest the Tru-Hitch on the transport legs. (you may also need to *extend* the mast slightly to support the Tru-Hitch* on the legs)

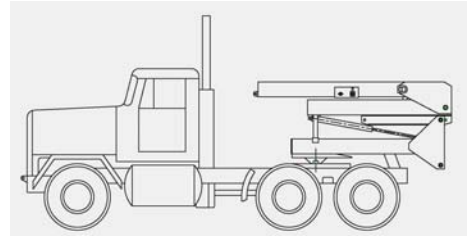

B. Use the control levers to *retract* the boom. (Boom Extensions should be fully retracted when performing this step.) Retract until the boom (3) is vertical and resting against the Mast Section (4). **Watch overhead for obstacles when performing this function.**

C. Use the control levers to *extend* the mast until the pivot arrow on the mast lines up with the Pivot Hole (14) and insert both pins. (Safety clevises (16) should be removed for this step)

D. Once pinned, *retract* the mast to fold the Tru-Hitch onto the tractor. *Retract* until the pivot pins loosen and can be removed.

E. *Extend* the mast until the supports reach the stops at the front of the fifth wheel section. (Do not over extend the mast as the supports can be bent if you extend too far)

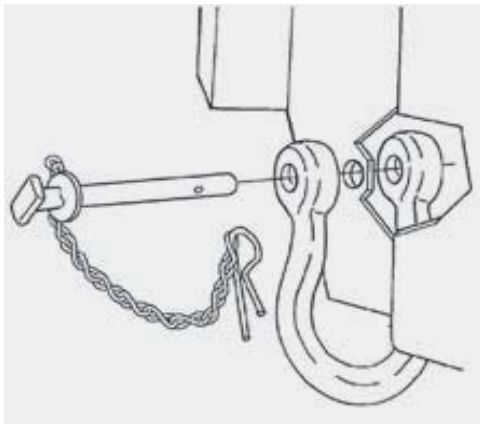

F. Install the safety clevises in the holes at the end of the mast track and cross chain
Safety Clevis

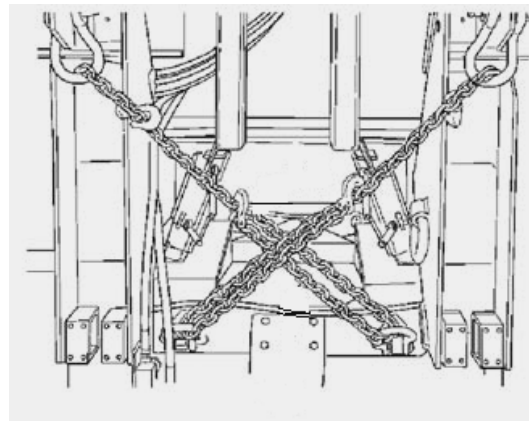

Transport Cross Chain

to the rear of the tractor taking up as much slack as possible. Then using valve control levers *retract* the mast slightly to tension the chains.

G. The Tru-Hitch is now ready for transport.

3. Procedure to fold the Tru-Hitch down for towing from the transport position

A. Using the valve control levers *Extend* the mast slightly to loosen the safety chains. Remove the chains and safety clevises.

B. Using the valve control levers, *Retract* the mast until the pivot arrow on the mast lines up with the pivot hole (14) and insert the pins.

C. Using the valve control levers, *Extend* the mast until it is vertical, in the track on the fifth wheel section, and the pivot pin loosens. Remove the pins.

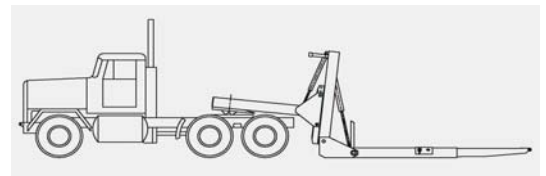

Procedure to fold the Tru-Hitch down for towing from the transport position- continued

D. Using the valve control levers, *Retract* the mast until it fully engages the track on the fifth wheel section. Install the safety clevises.

E. Using the valve control levers, *Extend* the boom until it is horizontal to the ground.

F. If necessary, *Retract* the mast to bring the boom section about an inch off the ground. (If you are always using the same tractor for towing, you will set the mast in the correct position during step D so that booms will end up an inch off the ground each time you perform step E.)

G. The Tru-Hitch* is now ready to back under the vehicle to be towed.

4. Procedure to load a truck on the Tru-Hitch*

A. Position the tractor with the Tru-Hitch* folded down so that it can be backed straight under the truck to be transported, or so that the truck can be winched straight over the booms.

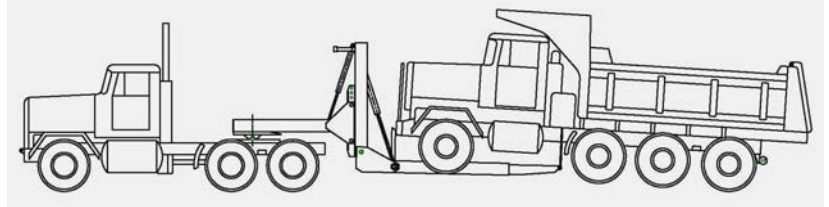

B. Place the receivers (11) in the hole setting that allows the wheel stops to contact the wheels on the towed vehicle while keeping clearance between the front of the towed vehicle and the bumper stops on the Tru-Hitch*. Be sure to fully engage all of the pins that hold the receivers on the boom.

C. Carefully back the Tru-Hitch* under the truck until the wheel stops contact the tires of the truck, making sure there is clearance between the boom and the truck. Make sure there are no obstructions before backing the boom under the truck's carriage. If necessary the winch (17) on the Tru-Hitch can be used to pull a truck over the booms when backing under the truck to be towed is not practical.

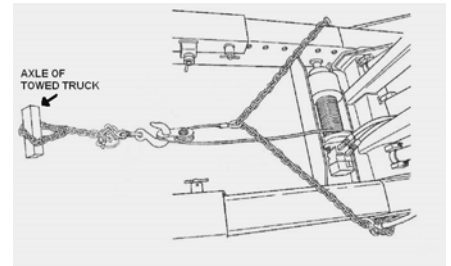

Winching setup

D. Using the valve control levers *Extend* the boom extensions (9) to the points where rear hook-up chains will be fastened to the truck.

E. Using the valve control levers, *Extend* the boom allowing the transport legs to clear the after frame of the tractor and to be raised by turning the handle counter-clockwise. The boom may raise the truck slightly when positioning to raise the transport legs. Make sure the truck is secure from moving and that the boom only contacts the axle(s) if this happens. **Note: Never tow with the transport legs in the down position.**

F. Using the valve control levers, *Retract* the boom to bring the boom extensions as close to the rear hook-up point as possible without interfering with any of the components of the trucks undercarriage.

Procedure to load a truck on the Tru-Hitch*- continued

G. Attach the rear hook-up chains to the boom extensions by using the ½” hook-up chains, the frame hooks, or combination as needed. See the photos of acceptable hookups in safety section. **Note: Never wrap a chain around an individual frame flange or cross member flange.**

H. Using the valve control levers, *Extend* the boom to tension the hook-up chains, and then lift the truck by contacting the axle resting on the boom. Be sure that the booms do not interfere with any other components under the truck. *Extend* the boom until the truck is lifted off the ground and the fifth wheel section is as level as possible. Place the boom lock pin in the hole that is visible at that point and then *Retract* the boom to set the weight on the pin.

I. If additional towing height is needed, *Extend* the mast to gain that height and then place pins in the mast using the half hole rest just above the pivot hole. Once pinned, *Retract* the mast to set the weight on the pins.

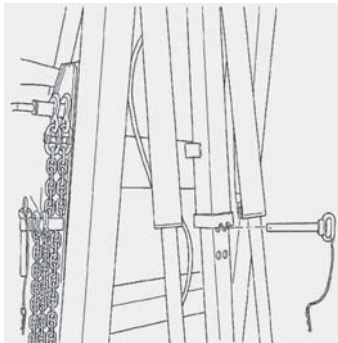

Boom lock

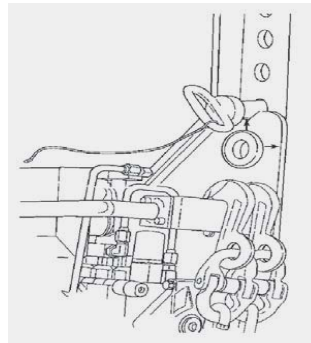

Mast lock in half hole

J. Attach left and right 3/8” front safety chains to hold tires of the truck to be towed securely against the wheel stops. Additional chains may be used as needed to secure the

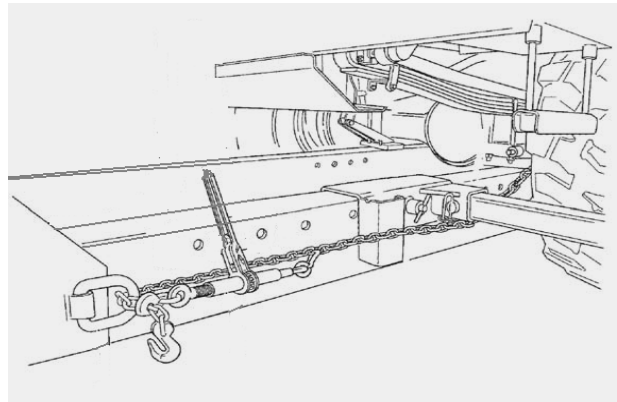
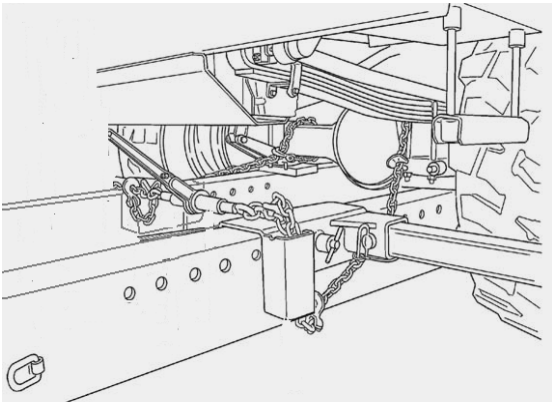

Safety chaining options

truck to the boom. Only grade 80 chain of sufficient size should be used to secure trucks to the Tru-Hitch*.

K. Hook up light bars and brakes as needed for towing.

L. Truck is ready for transport.

PERFORMANCE OF PRE-PICKING LIFTS

When additional axle clearance is needed, pre-picking operations can be performed with the fifth wheel towing device initially in the coupled configuration with the booms 1 inch and parallel to the ground. Adjust booms as needed to perform the steps.

1. Position tractor with the Tru-Hitch* unfolded as described above in front of disabled vehicle.
2. Using the valve control levers, *Extend left and Extend right* boom extensions out. Extend until the boom extensions pass under the front axle and are extended under and approximately 1 foot to the rear of the front axle U-bolts or cross members.
3. Place one 2-inch block or rubber pads between the U-bolt ends and the boom extensions, if necessary.
4. Using the valve control levers, *Extend* the boom until the transport legs are clear of the tractor after-frame. Rotate the handle counter clock-wise to raise and lock the legs in the stowed position.
5. Place one of the 6 inch blocks (or a full length 6X6) under each boom assembly, near the rear boom cross member, to create a pivot point.
6. Using the valve control levers, *Retract* the boom which will begin to raise the towed vehicle in the air. Be sure that all blocks stay in place. Raise the vehicle until the front tires are approximately 7-8 inches above the ground.
7. Insert the second set of 6 inch blocks under the front tires of the disabled vehicle.
8. Using the valve control levers, *Extend* the boom until the front wheels of the vehicle are resting on the 6 inch blocks, the booms are free of the U-bolts (front axle), and the 6 inch pivot blocks under the booms are free. Remove the pivot blocks.
9. Place the transport legs back in the down position.
10. Using the valve control levers, *Retract* the boom until the hitch rests on the transport legs and the booms are again 1 inch and parallel to the ground. *Retract left and right* extensions.
11. Continue with hook up for towing.

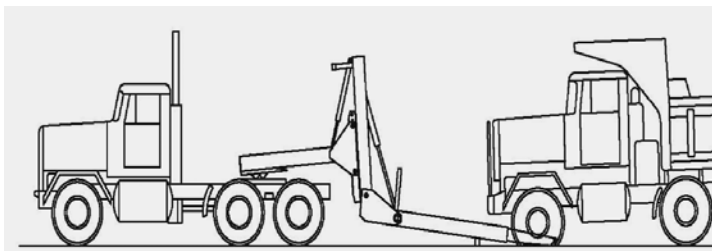

Pre-pick setup

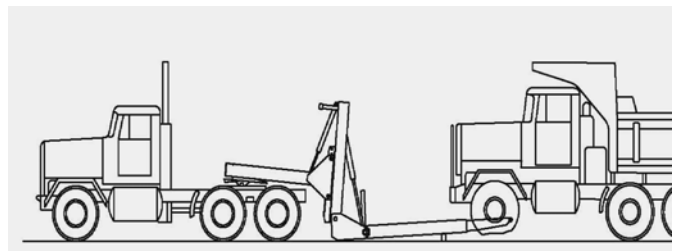

Pre- Pick

TRU-HITCH* SAFETY PRECAUTIONS

1. Operate Tru-Hitch* only after you have read and understand all instructions.
2. Hook and unhook Tru-Hitch* on a level surface
3. Chock wheels of truck before loading.
4. Lock and check fifth wheel coupling after hooking up to the Tru Hitch*.
5. Never travel with booms in the vertical position.
6. Check for obstructions before backing under the truck to be transported.
7. The distance between the lift point and the rear hook-up chains must be $\frac{1}{4}$ of the distance from the king pin to the axle on the ground being towed.
8. Never secure rear hookup chains around frame flanges.
9. Never tow a truck with the rear transport legs in the lowered position.
10. Engage the Boom lock and Mast lock pins to support loads when towing.
11. Front safety chains must hold vehicle being transported in a locked position.
12. Always couple tractor brakes and proper lighting to the truck being towed.
13. Always use safety clevises in the mast section for your safety.
14. Wetline connect couplers must be coupled at all times. Never dead-end them.

ACCEPTABLE REAR HOOK-UPS METHODS



FRAME HOOKS



Sling Hook end to a suitable structural member. Grab Hook end to chain from boom extensions.



GRAB HOOK TO FLANGE WITH VERTICAL PULL



OR CHAIN(S) OVER BOTH RAILS

NOT ACCEPTABLE



NEVER WRAP A CHAIN AROUND AN INDIVIDUAL FRAME FLANGE